

# Development of a lightweight strut made of composite material for the aviation industry

Martin Welsch & Ralph Funck  
CirComp GmbH  
Marie-Curie-Str.11  
67661 Kaiserslautern, Germany  
www.circomp.de

**Abstract—** The publication deals with the development of a composite landing gear component for aircrafts. The strut is manufactured with a new hybrid manufacturing process based on FilaWin® and RTM technology. Due to the lay-up and the component geometry, high tensile and compressive loads can be transferred. The compressive and torsion properties can be adapted to the component requirements by means of a suitable lay-up.

**Keywords—** Composite material, Strut, Landing gear, I-Rod, FilaWin®, RTM, Aviation

## I. INTRODUCTION

The aerospace industry is demanding higher stiffness, strength, weight and corrosion resistance. In addition to these aspects economic efficiency plays an important role, too. Thus the aim is to develop components with better or equal properties at lower weight and, if possible, lower costs. To meet these challenges it is essential to develop components made of new lighter materials such as fibre-reinforced composites. Landing gear components of aircrafts (e.g. linkage or brace) or helicopters (e.g. trailing arm) are mainly made of standard metallic materials. New developments of such components made of fibre-reinforced composites are already available. In addition to the mechanical properties of the landing gear components the focus will be on the development of a new hybrid manufacturing process consisting of the filament winding technology and the RTM (Resin Transfer Moulding) process. The developed component is subsequently called I-Rod.

## II. STATE OF THE ART

According to the current state of the art landing gear components are mainly manufactured out of titanium or 300M alloy or similar. However the trend is moving towards more powerful and lighter materials. From an economic point of view 300M is a very good material but the corrosion resistance is not ideal for the application [1].

In order to meet the requirements developments take place in the following fields [2]:

### A. Polymer Matrix Composites (PMC):

Composite materials (e.g. fibre-reinforced composites) provide the advantages compared to conventional material of weight, fatigue strength and corrosion resistance (using the correct material combination). In general components for landing gears are manufactured by means of a fibre preform and the post-process RTM. Several fibre composite prototypes are presented in [3], [4] [5] and [6]. For example, a drag brace for the F16 fighter jet or a trailing arm for the NH-90 helicopter are shown.

### B. Titanium Metal Matrix Composites (TiMMC):

TiMMC is a composite material consisting of titanium with an additional reinforcement such as fibres. For example a SiC (silicon carbide) fibre could be used. This material combination is particularly suitable for applications where an extremely high stiffness is required [5]. A major disadvantage of TiMMC is the high cost of production.

### C. High-strength stainless steels:

In the field of high-strength stainless steels new materials have been developed which have got higher strengths, excellent corrosion resistance and higher fracture toughness compared to known materials (e.g. X1CrNiMoAlTi12-11-2) [2].

Fig. 1 shows an overview of materials which are suitable for landing gear components.

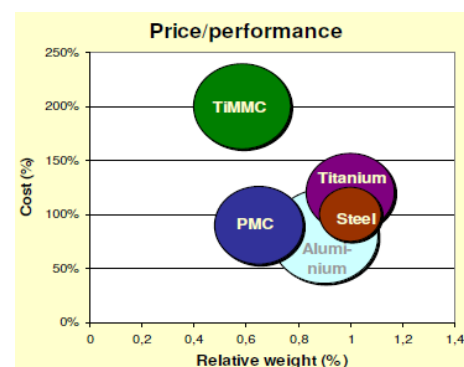

Fig. 1: Comparison of costs and weight savings for different materials [5]

It can be seen that polymer matrix composites (PMC) have a weight advantage of approx. 40% and a similar price level as conventional materials.

### III. I-ROD DESIGN AND MANUFACTURING CONCEPT

A simplified geometry is chosen for the production of a first I-Rod prototype. Fig. 2 shows the 3D model of the developed component.

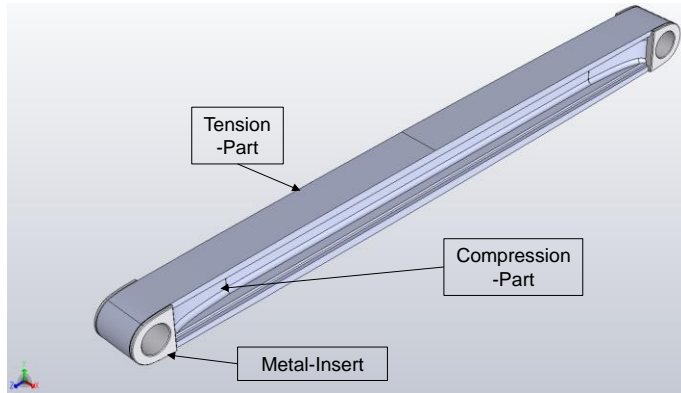

Fig. 2: 3D-Model of the composite I-Rod

The main dimensions of the I-Rod are as follows:

- Eye diameter 20mm (load transmission)
- Length Eye to Eye 453mm
- Height ca. 31mm
- Width 30mm (laminate)

The component consists of a tension belt for the transfer of tensile loads and a web for the transfer of compressive loads. The FilaWin® technology is predestined for the production of the tension belt as an endless fibre-reinforced loop connection. The web is manufactured with the RTM process. The load is applied through metallic inserts (e.g. made of titanium).

Depending on the requirements of torsional stiffness, buckling stability etc. the lay-up for the compression web and the material can be varied. For the first prototypes a 0/90° lay-up is used.

A quasi UD-layer structure is chosen for the tension belt. As a result the fibres lie optimally in the load path.

### IV. PROPERTIES OF THE I-ROD

Fig. 3 shows an I-Rod prototype produced by the hybrid manufacturing process described above and painted afterwards.



Fig. 3: I-Rod prototype

TABLE 1: MECHANICAL PROPERTIES OF THE I-ROD

Young's modulus <sub>axial, tension</sub> [GPa]	155
Young's modulus <sub>axial, compression</sub> [GPa]	61
Shear modulus G [MPa]	2800
Shear strength [MPa]	90
Weight m [g]	431,5

Depending on the lay-up of the web the compression modulus of elasticity and shear modulus can be adapted to the part's requirements. With a ±45° lay-up the shear modulus would be theoretically 29GPa and the shear strength 480MPa.

### V. STATIC TENSILE-/ COMPRESSION TEST

Manufactured prototypes are subjected to a static tensile and compression test. For this task an AllroundLine Z250 SE from Zwick/Roell is used. The following test procedure is chosen:

1. Applying a pre-force of 250N with a speed of 10mm/min.
2. Start the test up to fracture with a test speed of 8mm/min.

Table 2 shows the maximum reached loads of the I-Rod.

TABLE 2: RESULTS OF THE TENSION AND COMPRESSION TEST

Max. compression load [kN]	65
Max. tension load [kN]	247

A comparable aluminium rod would have got a 50% higher weight to carry the same loads. It can be seen that there is a high potential for fibre reinforced composite components in the field of aircraft and helicopter landing gears.

## VI. CONCLUSION

The project I-Rod deals with the development of a simplified strut for aircraft landing gears made of fibre reinforced composite. The current state of the art shows that the trend is moving towards lighter and highly robust structures. From an economic point of view components made of fibre reinforced composite are slightly higher in price than conventional metallic components but offer a weight advantage of approx. 50%.

The developed component is manufactured with a new hybrid manufacturing process consisting of the FilaWin® technology and the RTM process. The tensile load is transferred via a quasi UD loop connection. With the given geometry the maximum tensile load is 247kN. The compression load is transmitted via an I-profile with a 0/90° lay-up. Compression loads of up to 65kN can be achieved. In order to be able to transfer the same loads with aluminium component the component would have an additional weight of approx. 50%. It can be seen that there is a high potential for fibre reinforced composite components in the field of aircraft and helicopter landing gears.

## REFERENCES

- [1] Trends in landing gear material; Aeospace Engineering; September 2005
- [2] New Landing Gear Materials; The Shot Peener; 2011
- [3] H.G.S.J. Thuis - The development of composite landing gear components for aerospace applications; National Aeospace Laboratory NLR; April 2004
- [4] H.G.S.J. Thuis – Development of a composite torque link for helicopter landing gear applications; National Aeospace Laboratory NLR; ICCM-12; 1999
- [5] T. Sijpkens, P. Vergouwen – Composite materials for structural landing gear components; 30<sup>th</sup> European Rotorcraft Forum; ERF 2004
- [6] E. Leung, R. Rochette – The Development and Certification of Composite Landing Gear Components; Sampe UK & Ireland; SAFRAN, Messier-Bugatti-Dowty; February 2013